

Section 10

Cyclic, Collective, and Directional Controls

Procedures covered in this section:

Construct and install cyclic, collective, and directional controls.

Cards used in this section:

E14 CARD 1T	E14 CARD 4T	E16 CARD 1T	E24 CARD 2T
E14 CARD 2T	E15 CARD 1T	E16 CARD 2T	
E14 CARD 3T	E15 CARD 2T	E16 CARD 3T	

Prints used in this section:

E14-2000	E16-2000
E15-2000	

Templates used in this section:

E14-2
E16-1
E16-2

Tools required for this section:

Air or electric drill	Framing square	Pliers	Tap handle
Band saw	Grinder	Pop rivet gun	Vise
Files	Handsaw	Taps: 10-32, 1/4-28	Vise grips

Drill bits of the following sizes: 1/8", 3/16", 13/64", 1/4", # 21, Letter "D"

Ratchet with sockets of the following sizes: 3/8", 7/16", 1/2"

Wrenches of the following sizes: 3/8", 7/16", 1/2"

Notes:

1. **CYCLIC CONTROL:** When mounting the clevis to the shaft, make sure that there is a minimum of end play on the cyclic clevis and that there is no excessive pre-load on the pivot bushings.
2. **COLLECTIVE CONTROL:** The collective stick action and twist grip throttle action must function smoothly. Any roughness or binding will make flight operations extremely difficult, especially for the novice pilot.
3. **DIRECTIONAL CONTROL:** The foot pedals must operate smoothly and without excess friction throughout their entire range of travel.
4. **OFFSET PEDALS:** The offset pedals were designed to provide a wider and more comfortable foot position for the pilot. Install the standard pedals on the inside positions and the offset pedals toward the outside as shown in the illustration below.

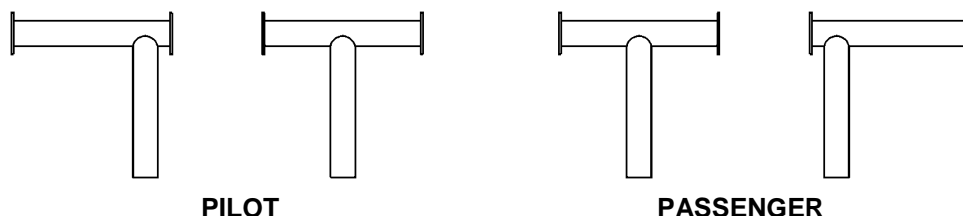

5. **CYCLIC CABLE ROUTING:** The drawing below shows an overall view of how the cyclic cables should be routed from the controls to the rotor hub assembly. There should be no sharp bends or kinks.

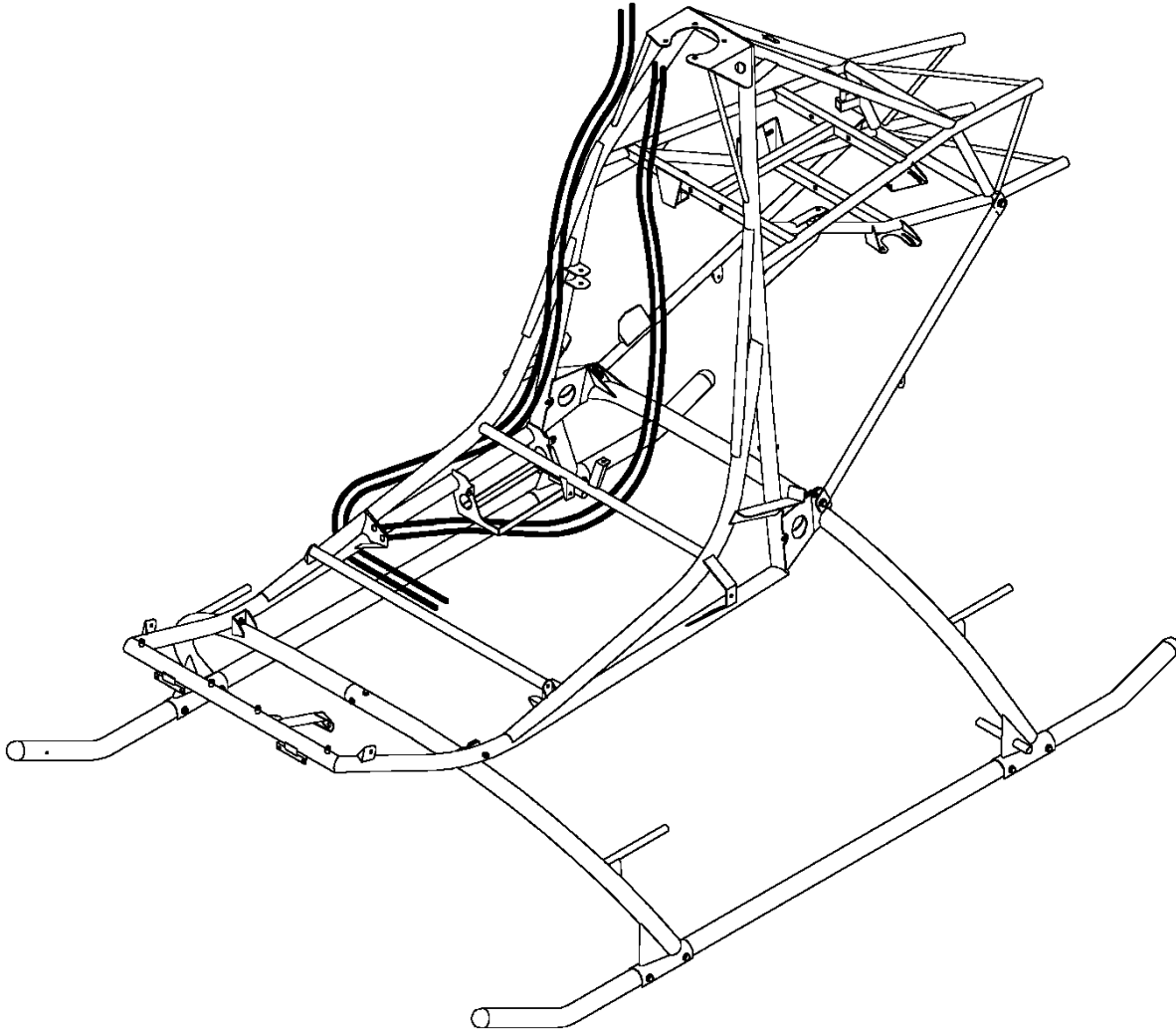

CYCLIC HANDLE

Photo #1

Position the handle on the cyclic stick according to pilot's preference. The end of the stick should extend at least 1/2 inch past the bolt hole in the aluminum sleeve in the handle. Mark the location of the bottom screw hole on the stick, remove the handle and drill.

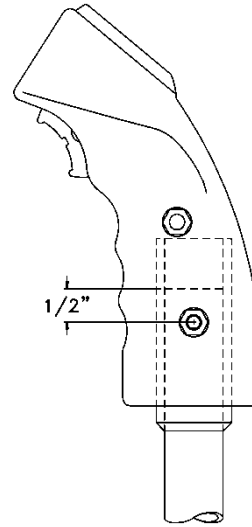

Photo #2

The rocker switch can be wired to activate the radio and intercom. Route the wires through the cyclic stick.



Photo #3

Install the starter button and starter switch cover on the top cap of the pilot's handle. Use two 3/32" pop rivets to hold the cover in place. Install the wiring and route the wires through the cyclic stick. Cover the wires with heat shrink to prevent chafing where they contact screws and sharp edges. Assemble the handle on the stick and install the screws and locknuts. E35-8550, E35-6200 located on E35 CARD 1T.





CYCLIC CONTROL

Photo #4

This photo shows the installation of the cyclic from the pilot seat. The push button for the starter will be installed in the pilot's cyclic handle when the wiring harness is installed. Take care to insure that the wires do not fray where they exit the cyclic stick. This could cause a short, resulting in starter engagement at full RPM during operation.

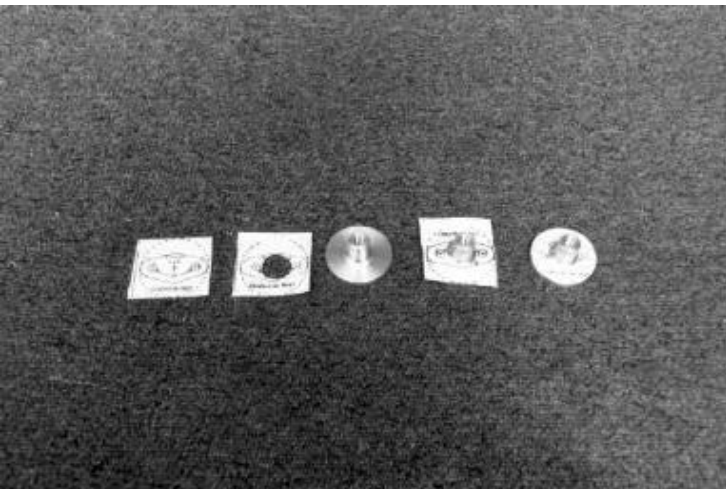

Photo #5

Using template E14-2, cut out and drill the holes in the push/pull control cable "T".

Note: Verify the 1-1/4" measurement before drilling.



Photo #6

Install the aluminum and nylon bushings on both cyclic control brackets on the airframe.

Note: Before cutting the cyclic control tube to length, the front landing gear and seat must be temporarily installed and tightened in place. Failure to do this will give the wrong length to cut the cyclic control tube. Check the length of the cyclic shaft by holding it next to the pivot bushings. Cut it to length for a snug fit. Cut both ends of the shaft if necessary to keep the center of the shaft on the aircraft's center line.

Photo #7

Opposite end shown for better understanding. After fitting the shaft, cut or grind the cyclic clevis bushings on the shaft to fit the clevis. Drill the bushings with a letter "D" drill bit to ensure a close tolerance fit with the bolt.



Photo #8

Exploded view of the bolt, nut, washers, and nylon bushings that hold the cyclic clevis to the shaft.

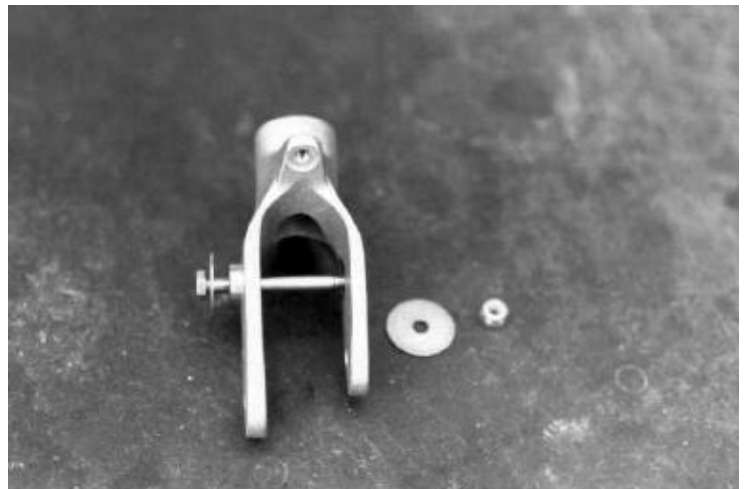

Photo #9

Make a slot 1/4" wide x 1/2" long in the pilot's cyclic stick just above the clevis to route the starter button wiring. (This photo shows the cyclic control assembled to clarify wire routing.)



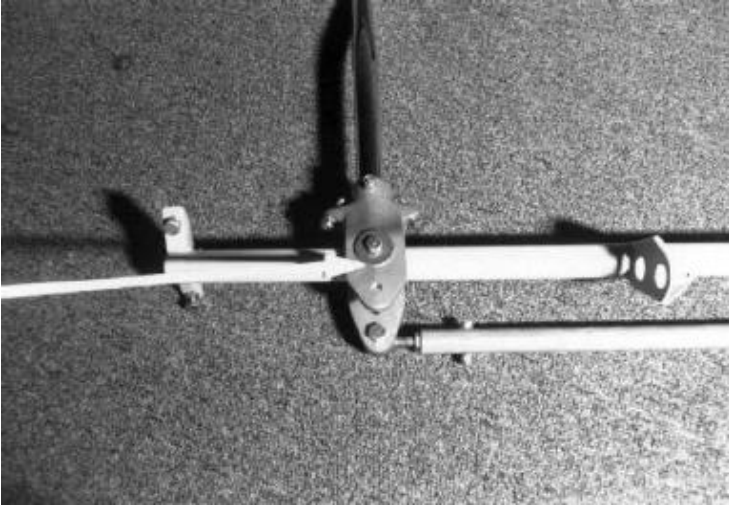

Photo #10

On final assembly, apply grease to all moving parts. Check that the pivot bolt is tight. The large fender washer should be as close to the side of the clevis as possible without touching.



Photo #11

Install the cross tube in the airframe to make the correct stick travel adjustments. Use the bolts where the arrow indicates to set the lateral cyclic stick travel.

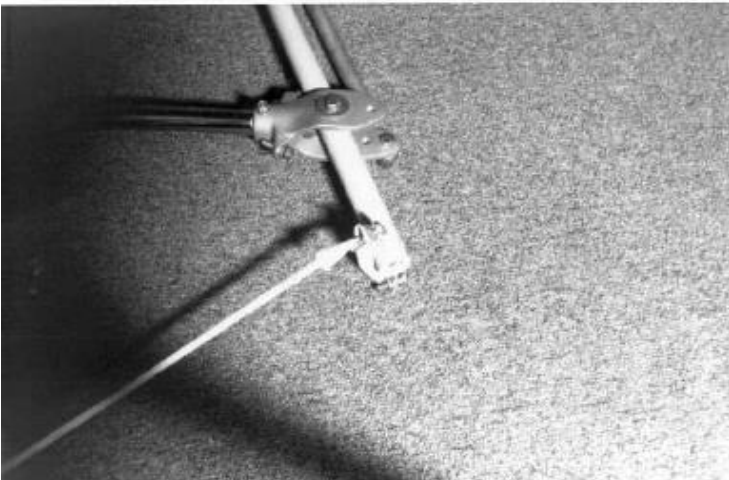

Photo #12

Use the bolts where the arrow indicates to set the fore and aft cyclic stick travel.

Photo #13

On final installation, be sure to apply grease between the aluminum control bushings and nylon pivot bushings.

Note: Make sure that the cyclic shaft is able to rotate freely without binding and without any excess side-to-side play.

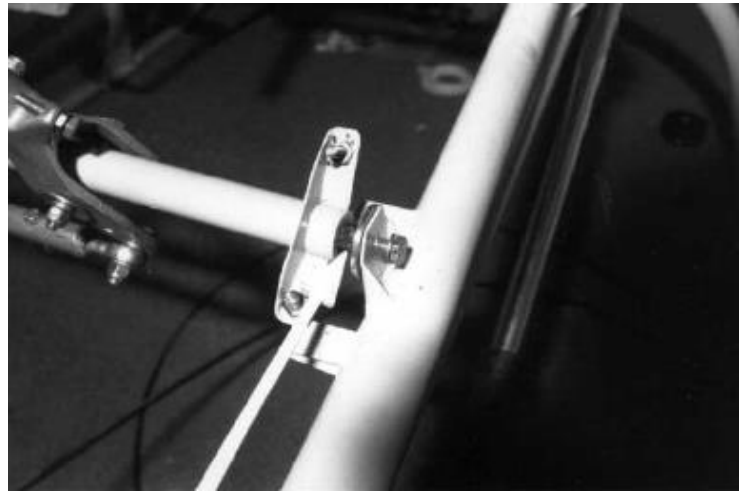

Photo #14

On final assembly, apply Loctite 242 to the threads of the end bolts and make sure they are tight.



Photo #15

On final assembly, safety wire the bolt to the airframe bracket. (See Standard Construction Procedures for safety wiring methods).

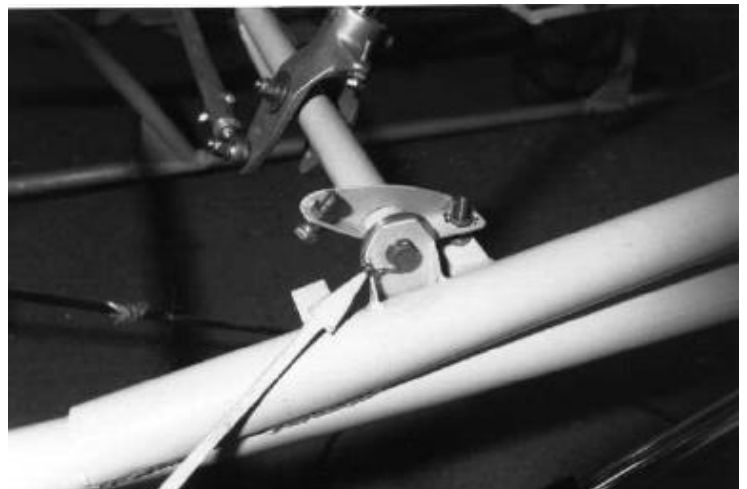

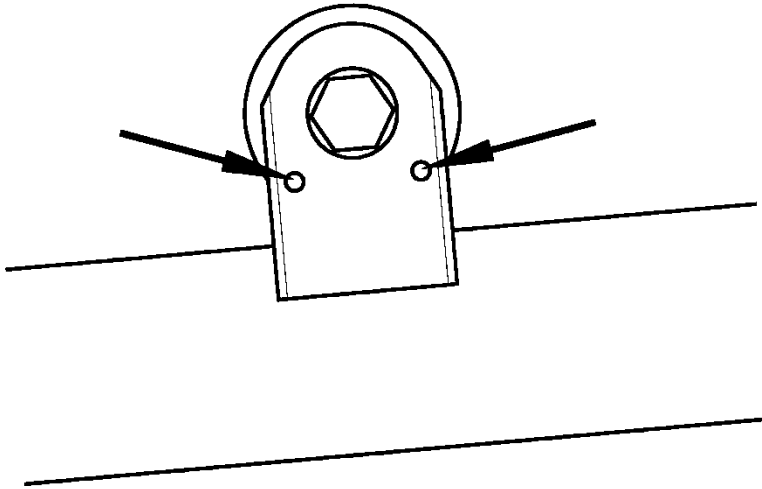

Photo #16

On final assembly drill two 1/8" holes through the aluminum bushings and airframe brackets and install pop rivets in each. Make sure that the rivets do not interfere with the nylon pivot bushings.



Photo #17

Install the cyclic control cables. This is a close-up view of the cyclic control. Check security of all stop nuts and tightness of all mounting hardware in the cyclic control system, including the double nuts which secure the cables to their mounting brackets. Check full travel of the control for freedom of movement.

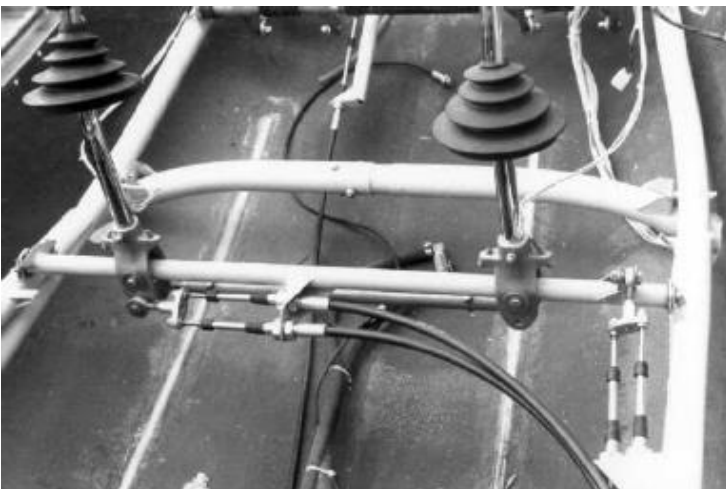

Photo #18

Overall view after final installation in the airframe.

Check full travel of control for freedom of movement.

Photo #19

Route the lateral cyclic cables as shown to prevent kinking and interference with the gas tank.

Note: Refer to page B of this section for an overall view of the cable routing.



Photo #20

Install cushion loop clamps on the 1" airframe support tube (passenger side) to retain the cables. Wrap on clamp around the tube and the other around the cables, joining them together with a 3/16" bolt. Exact location may vary. E14 CARD 1T.

Note: Proximity to the torque link bracket, shown at the bottom of this photo.



COLLECTIVE CONTROL

Photo #21

Exploded view of the throttle and collective control.





Photo #22

The seat bulkhead must be installed so that the collective cross tube can be fitted. Cut holes in the back of the seat bulkhead where the pilot and passenger collective stick will come through. The openings should be as small as possible, and can be enlarged after the collective is installed.



Photo #23

Cut or grind the overall length of the collective cross tube to fit between the mounting brackets on the airframe. Include the thickness of the nylon and aluminum bushings when determining the fit. Trim from each end as necessary to make the passenger stick centered in the channel in the floor. The pilot's stick will be approximately 1/4 inch off center towards the middle to provide additional hand clearance for the pilot.

Note: If necessary, the bushings can be shortened slightly to fit into the ends of the cross tube after it is trimmed.



Photo #24

Drill the throttle handle, end plug, and throttle shaft for the roll pin.

Photo #25

Completed throttle shaft with handle.



Photo #26

Do not cut off the excess rubber from the grip. This helps put some friction in the system so that the pilot may at times remove his hand from the collective without the throttle rolling off.

Note: An easy way to install or remove the rubber grip is to use an air nozzle to blow air into the small hole in the end of the grip.



Photo #27

Install the throttle shaft into the control stick. Locate and drill the 3/16" hole to attach the "B" control arm. Install the 3/16" bolt so that the head of the bolt is toward the throttle stop.



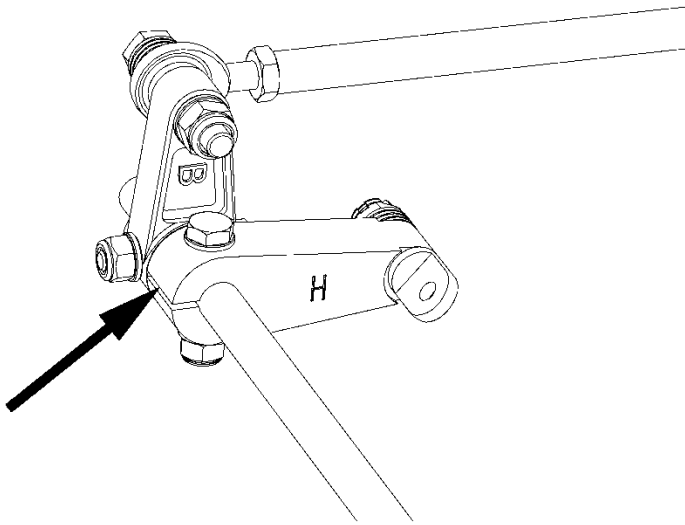

Photo #28

Cut a slot in the large end of control arm "H" as shown (arrow). Place control arms "B" and "H" on the transfer shaft at the angles and positions called for on print E15-2000. Drill the holes and install the bolts. The eye bolt on control arm "H" must be able to pivot freely.
E15 CARD 2T.



Photo #29

Install the transfer shaft assembly (shown in the previous photo) into the control stick stub, and locate and drill the 1/8" holes for the split pins.

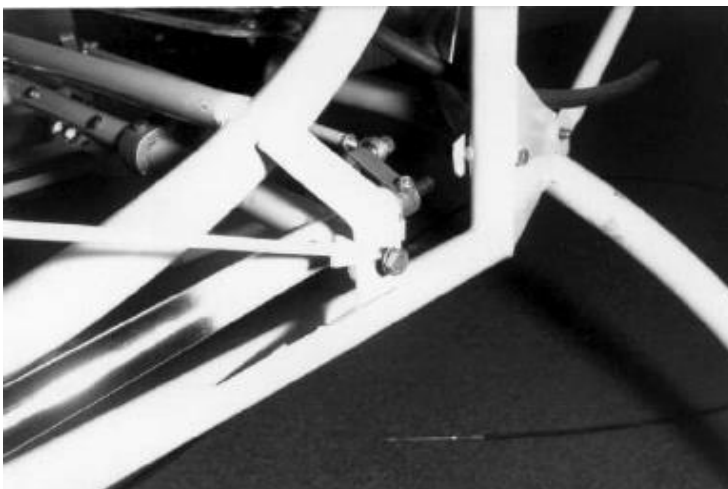

Photo #30

Install the collective assembly in the airframe. Apply grease between the nylon pivot bushings and the aluminum control bushings. On final assembly, apply loctite to the threads of the end bolts and then safety wire.

Photo #31

Install the throttle connector shaft weldment. As in all manually controlled helicopters, power is added by rolling the throttle outward and closed by rolling the throttle inward.

Make a template as shown to determine the angle of the "B" control arm. With throttle in the fully closed position, the "B" control arm on the pilot's side should be 17 to 18 degrees in reference to the collective cross shaft (see next photo).

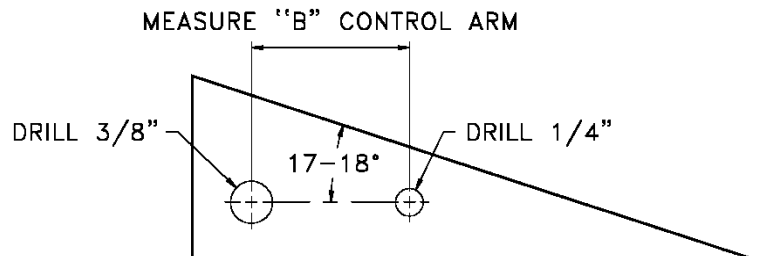

Photo #32

Adjust rod ends and throttle stops to achieve approximately 143° throttle roll (at full down collective). The fully closed throttle stops are the points indicated here by arrows. Both should make contact at the same time, and the template should be level, which verifies that the "B" control arm on the pilot's side is 17 to 18 degrees in reference to the collective cross shaft.

The fully open throttle stops are the points indicated here by arrows. Both should make contact at the same time. Stops can be ground or bent to achieve this.

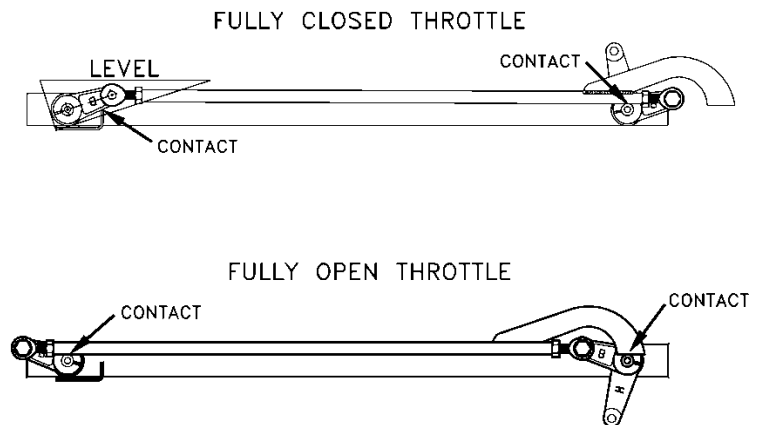

Photo #33

The collective should travel a minimum of 16" from full down to full up position. Open the holes in the seat bulkhead as necessary for full collective travel.





Photo #34

On final assembly, apply Loctite to the threads of the end bolts and tighten. Safety wire the bolts to the airframe brackets. Secure the aluminum bushings to the airframe brackets with rivets in the same manner as on the cyclic control (see Section 10, page 8, photo 16).



Photo #35

Install the throttle cable as shown. This is best left until after the engine has been installed. Collective handle position, throttle position and main rotor blade pitch must meet the correlation requirements outlined in Section 25, Collective Control Rigging.



Photo #36

Throttle cable shown connected to the collective.

DIRECTIONAL CONTROL

Photo #37

Place the templates on the scissor beams. Cut and drill as outlined. E16 CARD 3T

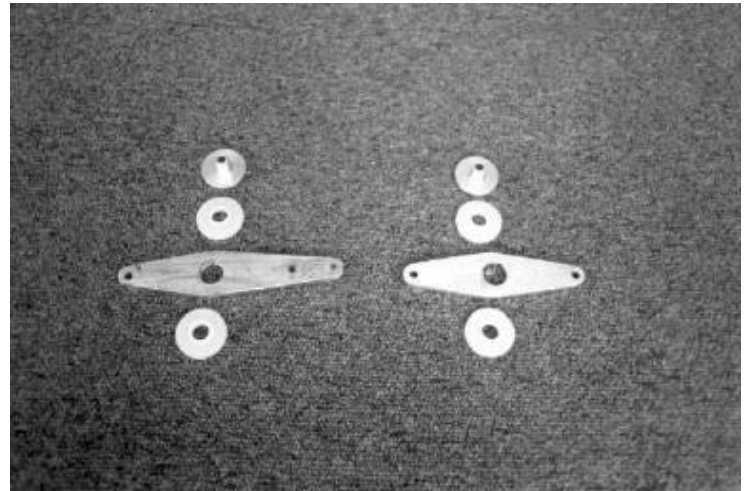

Photo #38

The two nylon scissor beam pivot bushings, the aluminum scissor beam pivot plug, and the scissor beams are shown here both exploded and assembled. The aluminum pivot plug must extend approximately .010" through both nylon pivot bushings so that the beam will pivot on the bushings and not on the bolt.

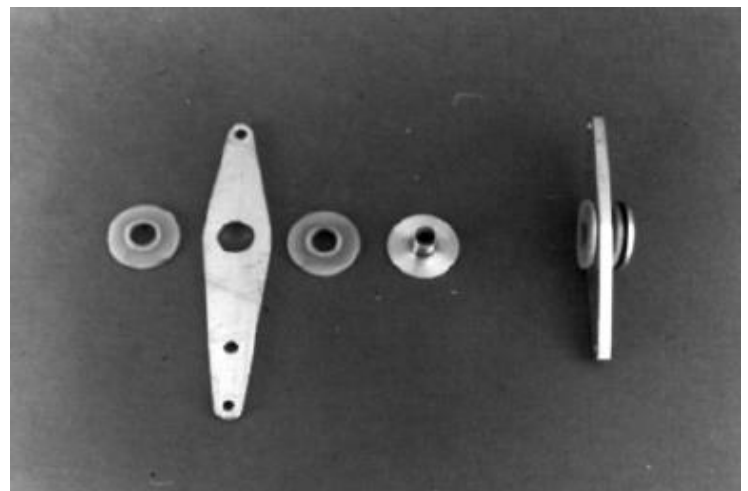

Photo #39

Exploded view of the assembly. The foot pedal castings must pivot freely on the cross shaft. If necessary, open the hole with a reamer or brake cylinder hone. Drill the pedal weldments and install them in the castings, as shown on Print E16-2000, E16 CARD 1T, and E16 CARD 2T.

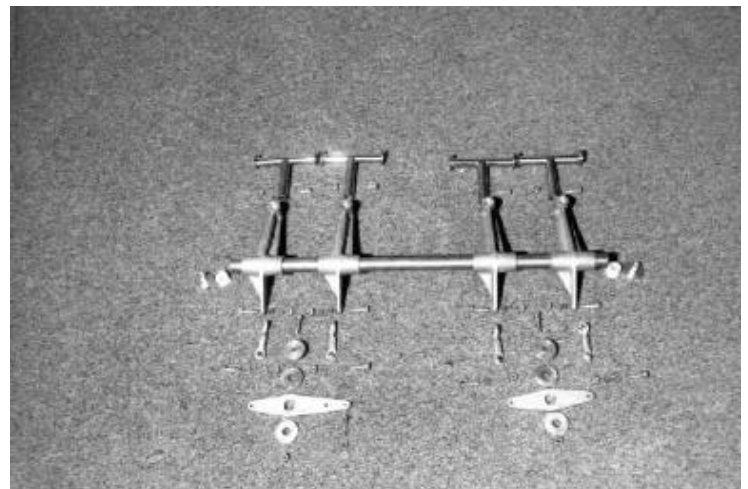



Photo #40

Apply grease on all mating parts in this assembly. Install the scissor beams on the bracket.



Photo #41

Install the stop bolts on the bracket as shown.

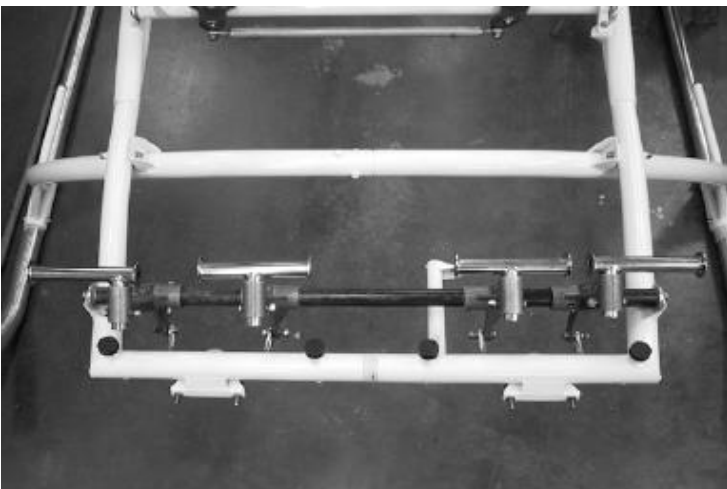

Photo #42

Fit the pedal shaft to the airframe brackets. Include the thickness of the aluminum and nylon bushings when determining the fit. Place the pedal castings on the pedal shaft and install the shaft on the airframe.

Note: It may be necessary to trim or grind off part of the aluminum bushing to fit the pedal shaft into position.

Photo #43

Install the directional control cable in the bracket and attach the rod end to the scissor beam. Move the scissor beam to the end of travel in the cable.

Set the stop bolt so it makes contact with the scissor beam.

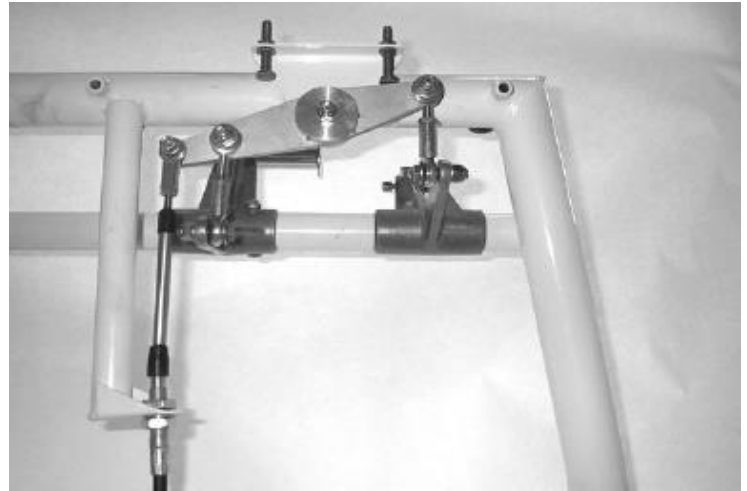

Photo #44

Move the scissor beam to the other end of travel and set the other stop bolt. Check the following:

When the scissor beam travels from stop to stop, the rod end on the directional cable must move a total of 2-7/8".

When the scissor beam is at the mid-point of travel, it should be parallel with the front cross tube of the airframe.



Photo #45

Position the pedal castings on the shaft for best alignment of the rod ends between the castings and the scissor beams (see print E16-2000). The distance between the pedal castings should be about 2-5/8". Fit the floor pan around the pedal castings for proper positioning.

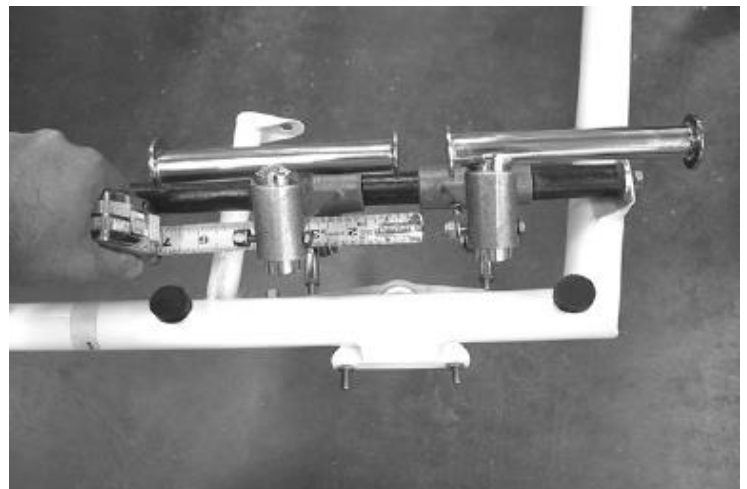

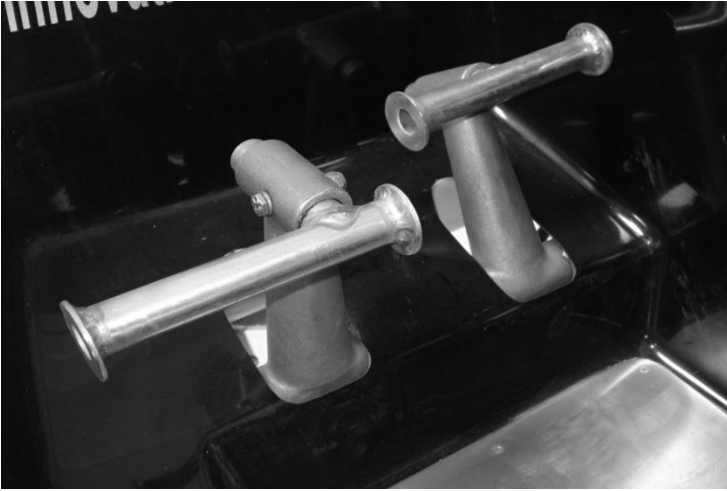

Photo #46

The right pedal is the one that will be bolted to the shaft. Do not drill this hole or place the spacer between the two pedal castings until after the holes in the floor pan are cut out as shown in the photo. When the floor pan is in place over the pedals, they may need to be slid from side to side for better positioning.

Note: When you are ready to cut the pedal holes in the floor pan turn pedals upside down. You can then lay the floor pan in position and mark the holes from the bottom side.

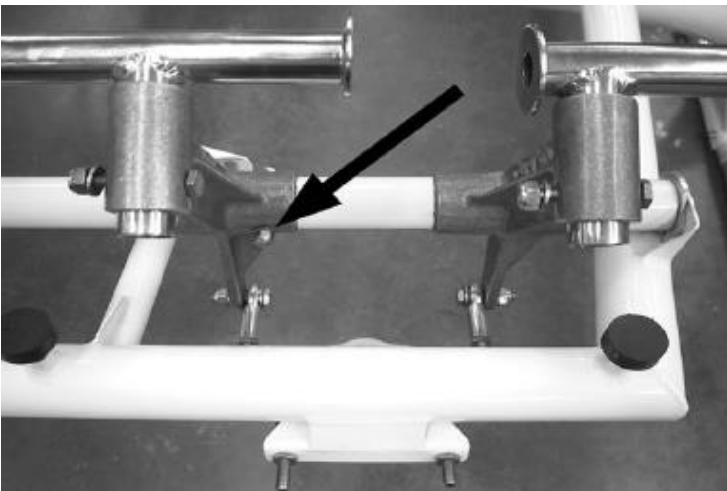

Photo #47

Once the proper position has been found, drill a 3/16" hole through the pedal and shaft and install the bolt. It should just be visible through the hole cut in the floor pan for the pedal. Do not forget to add grease.



Photo #48

On final assembly, apply Loctite to the threads of the end bolts and tighten them. Safety wire the bolts and pop rivet the aluminum bushings to the brackets.